

SM 1269-1

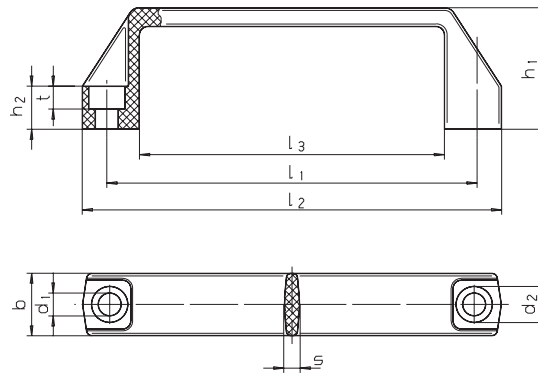

Bügelgriffe, Kunststoff

Cabinet "U"-handle, plastic



| Catalog No. | l ₁ | Material | Colour |
|-------------|----------------|----------|--------|
| SM 1269-1 | 094 | PA | OR |

PP: Kunststoff Thermoplast (Polypropylen PP), glasfaserverstärkt, matt temperaturbeständig bis 100° C

PA: Thermoplast (Polyamid PA) glasfaserverstärkt, matt temperaturbeständig bis 150° C

PA: plastic Technopolymer (Polyamide PA) glass fibre reinforced temperature resistant up to 150° C

PP: plastic Technopolymer (Polypropylen PP) glass fibre reinforced temperature resistant up to 100° C



SV = gemäß UL 94 V-0 als selbstverlöschend eingestuft, glasfaserverstärkt, matt temperaturbeständig bis 150° C
plastic self-extinguishing, glass fibre reinforced, temperature resistant up to 150° C

SW = schwarz / black RAL 9005 (PA/PP)
OR = orange RAL 9004 (PA)
GR = grau / grey RAL 7031 (PA)

Bügelgriffe SM 1269-1 können auch von der Bedienungsseite her angeschraubt werden können.

A characteristic of cabinet „U“ handles SM 1269-1 is that they can be screwed on from the operators side.

| l ₁ | | € | | | b | d ₁ ∅ | d ₂ ∅ | h ₁ | h ₂ | l ₂ | l ₃ | s | t | kg | |
|----------------|---------|-------|-------|-------|------|---------------------|---------------------|----------------|----------------|----------------|----------------|-----|-----|------|-------|
| | | SW | PA OR | GR | | | | | | | | | | | PP SW |
| 094 | - 1,0 | 2,17 | 2,32 | 2,33 | 1,87 | 21 | 6,5 | 10,5 | 38 | 13 | 109 | 74 | 6,0 | 7,0 | 0,022 |
| 117 | +/- 1,0 | 2,50 | - | - | 2,05 | 26 | 8,5 | 13,5 | 41 | 15 | 134 | 93 | 7,0 | 8,5 | 0,039 |
| | | 2,50 | 2,77 | 2,74 | 2,05 | | | | | | | | | | 0,042 |
| 122 | +/- 1,0 | 2,97 | - | - | 2,39 | 27 | | | 45 | 16 | 150 | 108 | | | 0,045 |
| 132 | +/- 1,0 | 3,99 | 4,28 | 4,24 | 3,42 | | | | | | | | | | 0,047 |
| 179 | +/- 1,0 | 4,68 | 5,03 | 5,20 | 3,99 | | | | | | | | | | 28 |
| 235 | +/- 1,0 | 10,07 | 10,07 | 10,08 | 9,32 | 30 | 10,5 | 16,5 | 54 | 20 | 260 | 201 | 8,5 | 10,5 | 0,118 |

SM 1269-2



Bügelgriffe, Kunststoff

Cabinet handles, plastic

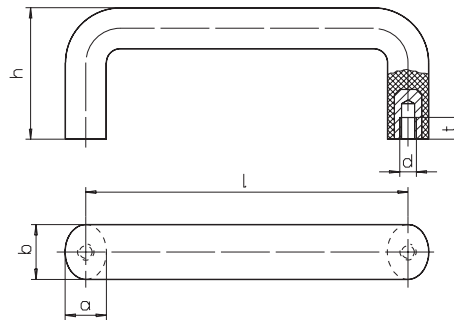

| Catalog No. | l |
|-------------|-----|
| SM 1269-2 | 086 |

Kunststoff (Duroplast PF) / plastic
 Buchse: Messing / bush: brass

Pressgrat sauber poliert, temperaturbeständig bis 110° C
fine polished, temperature resistant up to 110° C

schwarz, glänzend / black, shiny

mm



Pressgrat weder sichtbar noch fühlbar; das Finish genügt höchsten Ansprüchen. Durch den großen Querschnitt und die MS-Gewindebuchse wird eine gute Stabilität erreicht.

A special feature of cabinet „U“ handle SM 1296-2 is that the flash can neither be seen nor felt. The finish meets the most exacting requirements. Stability is attained due to the large cross-section and the bras insert.

| l | € | a | b | d ∅ | h | t | kg |
|-------------|------|----|----|--------|----|----|-------|
| 086 +/- 0,5 | 5,16 | 17 | 26 | M06 | 43 | 12 | 0,087 |
| 117 +/- 0,5 | 5,81 | 20 | 30 | M08 | 54 | 13 | 0,139 |
| 179 +/- 1,0 | 8,50 | 20 | 30 | M08 | 62 | 13 | 0,179 |