

4



Catalog No.	Form	l <sub>1</sub>	X	d
SM 1147	D	25	X	M12



Stahl  
steel



einsatzgehärtet und brüniert  
Gewinde weich  
case-hardened, blackened



mm



- Form A:** mit Außengewinde, Auflagefläche plan
- Form B:** mit Außengewinde, Auflagefläche ballig
- Form C:** mit Außengewinde, Auflagefläche geriffelt
- Form D:** mit Innengewinde, Auflagefläche plan
- Form E:** mit Innengewinde, Auflagefläche ballig
- Form F:** mit Innengewinde, Auflagefläche geriffelt

Verwendung als Auflagen, Anschläge und Druckstücke im Vorrichtungsbau und allgemeinen Maschinen- und Gerätebau.

- Form A:** with thread and plain surface
- Form B:** with thread and spherical surface
- Form C:** with thread and ribbed surface
- Form D:** with female thread and plain surface
- Form E:** with female thread and spherical surface
- Form F:** with female thread and ribbed surface

To be used as seats, stops and thrust pads.

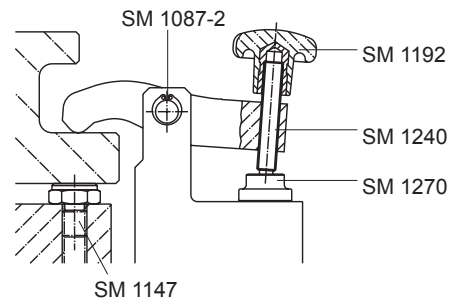
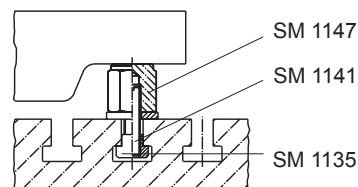

SM 1147

l <sub>1</sub>	d Ø	€			d <sub>1</sub> Ø	d <sub>2</sub> Ø	l <sub>2</sub>	t	SW	r	kg
		Form									
		A	B	C							
10	M08	9,56	8,12	9,23	17	19,4	20	-	17	30	0,024
	M10	10,02	8,62	9,35	19	21,7	22	-	19		0,030
	M12	10,73	9,32	9,72	22	25,2	24	-	22		0,040
15	M10	10,02	8,62	9,35	19	21,7	27	-	19		0,041
	M12	10,73	9,32	9,72	22	25,2	29	-	22		0,056
	M16	24,91	18,62	23,18	30	34,3	34	-	30	50	0,130
20	M16	25,47	19,07	23,97	30	34,3	39	-	30		0,155

l <sub>1</sub>	d Ø	€			d <sub>1</sub> Ø	d <sub>2</sub> Ø	l <sub>2</sub>	t	SW	r	kg
		Form									
		D	E	F							
15	M08	8,12	6,72	7,76	17	19,4	-	06	17	30	0,027
25	M08	8,41	6,92	7,96	17	19,4	-	16	17		0,040
20	M10	8,40	6,94	7,89	19	21,7	-	10	19		0,040
	M12	8,59	7,34	8,03	22	25,2	-	10	22		0,052
25	M12	8,82	7,39	8,19	22	25,2	-	15	22		0,065
	M10	8,73	7,28	8,06	19	21,7	-	15	19		0,065
30	M12	9,06	7,68	8,37	22	25,2	-	20	22		0,077
	M10	9,11	7,68	8,22	19	21,7	-	15	19		0,086
40	M12	9,56	8,17	8,85	22	25,2	-	25	22		0,105
	M10	9,90	8,57	9,35	22	25,2	-	25	22		0,135
50	M16	22,66	16,50	20,92	30	34,3	-	20	30	50	0,140
	M16	24,91	17,14	21,92	30	34,3	-	25	30		0,250