

Catalog No.	Form	d ₁
SM 1270-2	A	M06

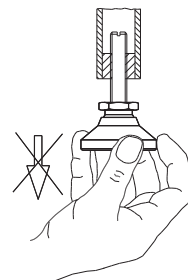

- Form A:** Kugelelement: Automatenstahl, induktivgehärtet, brüniert
Teller: Stahl vergütet, brüniert
- Form DN:** Kugelelement: Nirosta 1.4305
Teller: Thermoplast, weiß
- Form Ni:** Kugelelement: Nirosta 1.4305
Teller: Nirosta 1.4305
- Form A:** ball bearing: heat-treated blackened steel
pad: steel
- Form DN:** ball bearing: stainless steel
pad: Thermoplast (POM)
- Form Ni:** ball bearing: stainless steel
pad: stainless steel

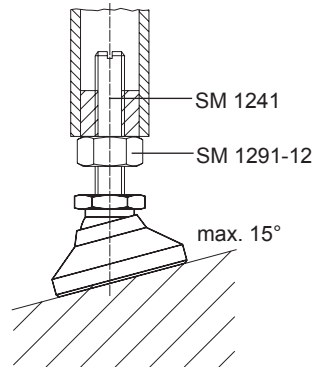

4



mm



Verwendung als FüÙe und Druckstücke. Sie können mit den meisten Schraubensorten verbunden werden. Temperatureinsatzbereich Thermoplastausführung von - 30 °C bis + 80 °C.

To be used as feet and thrust pads.



d ₁ Ø	€			d ₂ Ø	SW	h ₁	h ₂	t	F _{max} A [kN] stat.	F _{max} DN [kN] stat.	F _{max} Ni [kN] stat.	kg	
	Form A	Form DN	Form Ni									A	DN / Ni
M06	6,25	6,25	6,53	20	10	14	2,5	5,0	10	4	8	0,017	0,008
M08	7,03	7,03	7,59	25	13	18	4,0	7,0	18	7	14	0,037	0,017
M10	9,04	9,04	9,99	32	17	22	5,0	9,0	20	10	16	0,077	0,036
M12	12,39	12,39	13,17	40	19	26	6,0	11,0	35	18	28	0,125	0,054
M16	16,46	16,46	20,20	50	24	32	7,0	13,5	45	20	36	0,249	0,103
M20	21,71	21,71	25,00	60	30	42	8,0	17,0	55	22	44	0,478	0,205
M24	28,74	29,18	32,92	60	36	45	9,5	19,0	65	25	52	0,665	0,285