

# SM 1274-7

# Teilkolben mit Feder zylindrisch Indexing plunger, cylindrical

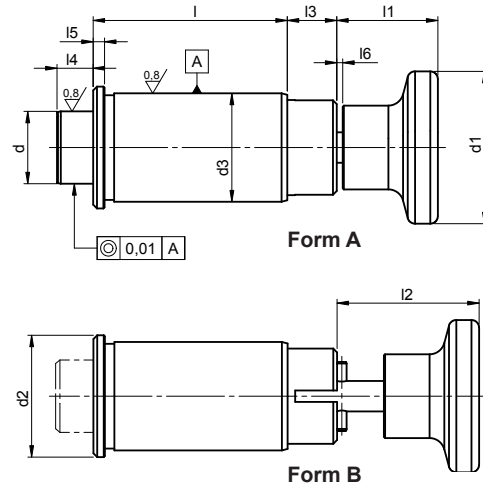

Catalog No. Form d  
SM 1274-7 A 19



Stahl, Griff Aluminium  
steel, grip from Aluminium



gehärtet und geschliffen  
hardened and ground



mm



**Form A:** Standard-Ausführung  
standard

**Form B:** arretierbare Entriegelung  
with lockable interlock  
release



RoHS  
Konform  
Compliant



| d<br>Ø | €     |       | d <sub>1</sub><br>Ø | d <sub>2</sub><br>Ø | d <sub>3</sub><br>Ø<br>p6 | l  | l <sub>1</sub><br>Form |    | l <sub>3</sub> | l <sub>4</sub> | l <sub>5</sub> | l <sub>6</sub> | kg    |
|--------|-------|-------|---------------------|---------------------|---------------------------|----|------------------------|----|----------------|----------------|----------------|----------------|-------|
|        | A     | B     |                     |                     |                           |    | A                      | B  |                |                |                |                |       |
| 13     | 57,54 | -     | 32                  | 22                  | 19,0                      | 35 | 20                     | -  | 13             | 9,5            | 3              | 1,5            | 0,120 |
|        | -     | 66,71 | 28                  | 22                  | 19,0                      | 35 | -                      | 31 |                |                |                |                | 0,120 |
| 19     | 73,24 | -     | 40                  | 32                  | 28,5                      | 51 | 25                     | -  | 13             | 9,5            | 3              | 1,5            | 0,335 |
|        | -     | 83,71 | 40                  | 32                  | 28,5                      | 51 | -                      | 36 |                |                |                |                | 0,335 |
| 25     | 86,99 | -     | 50                  | 42                  | 38,0                      | 58 | 32                     | -  | 13             | 9,5            | 3              | 1,5            | 0,635 |
|        | -     | 92,88 | 50                  | 42                  | 38,0                      | 58 | -                      | 43 |                |                |                |                | 0,635 |

# SM 1274-8

# Teilkolbenbuchsen zylindrisch Cylindrical bushings for indexing plungers

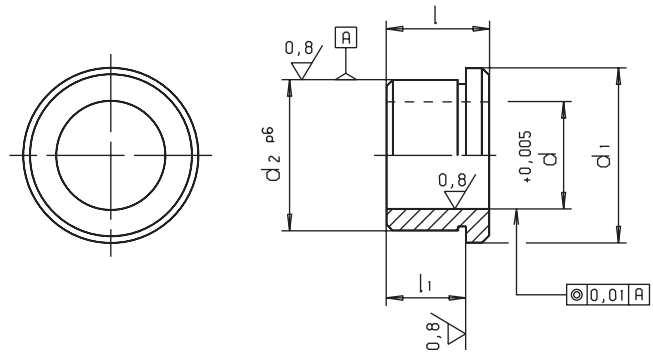

Catalog No. d  
SM 1274-8 19



Stahl  
steel



gehärtet und geschliffen  
hardened and ground



mm



RoHS  
Konform  
Compliant



Reinigen mit  
SM 1306  
Clean with  
Seite 360



Kleben mit  
SM 1300  
Lock with  
Seite 356



| d<br>Ø | €     | d <sub>1</sub><br>Ø | d <sub>2</sub><br>Ø<br>p6 | l  | l <sub>1</sub> | kg    |
|--------|-------|---------------------|---------------------------|----|----------------|-------|
| 13     | 9,57  | 22                  | 19,0                      | 13 | 10             | 0,015 |
| 19     | 14,26 | 32                  | 28,5                      | 16 | 13             | 0,045 |
| 25     | 17,67 | 42                  | 38,0                      | 19 | 16             | 0,100 |