

**Catalog No.** | **Form** | **d<sub>1</sub>**  
SM 1275-21 | A | M16



M08 - M12



M16



**Form A:** Hülse: Stahl  
Bolzen: Stahl gehärtet  
Federkraft: normal  
housing: steel  
bolt: free cutting steel, hardened  
spring load: normal

**Form N:** Hülse: Niosta 1.4305  
Bolzen: Niosta 1.4305  
Federkraft: normal  
housing: stainless steel 1.4305  
bolt: stainless steel 1.4305  
spring load: normal

**Form AS:** Hülse: Stahl  
Bolzen: gehärteter Stahl  
Federkraft: verstärkt  
housing: steel  
bolt: free cutting steel, hardened  
spring load: increased

**Ausf. SD:** Spezialschraubendreher  
special screwdriver

Dichtung / sealing = NBR plastic

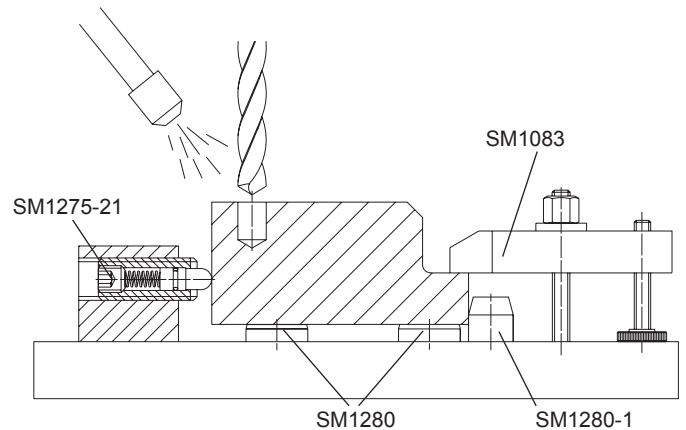

**Kennzeichnung:** Ausführung Automatenstahl verstärkte Federkraft = Gewindestift blank  
**Indication:** free cutting steel finish with increased spring load = threaded bolt, bright

Zur Arretierung sowie als An- und Abdruckstifte. Durch die Abdichtung wird das Eindringen von Flüssigkeit in das Druckstück verhindert. Montage, Demontage mit Innensechskant und Schlitz möglich.

Temperatureinsatzbereich: - 30 °C / + 80 °C.

Abweichungen bei Maß l, Federkraft und Temperaturbeständigkeit gegenüber Ausführung SM1275-2 „ohne Abdichtung“.

To be used for locating or for applying pressure or lifting off. By means of the seal, liquid cannot penetrate into the spring plunger. Spring plungers can be fixed and removed by means of the slot or internal hexagon.

Temperature range from - 30 °C up to + 80 °C.

Compared to finish of SM1275-2, i.e. „no seal“, there are deviations in dimension l, spring load and temperature range.



mm



d <sub>1</sub> ∅	€ Form				d <sub>2</sub> ∅	l	w	n	t	sw	Form A + AN		Form AS		kg
	A	AN	AS	SD							Druck / Pressure [N]		Druck / Pressure [N]		
											Anfang Start	Ende End	Anfang Start	Ende End	
M08	2,43	4,87	2,71	12,38	3,8	26	3,0	1,5	1,4	2,5	9	24	17	39	0,008
M10	2,71	5,48	3,04	12,38	4,0	28	3,5	1,5	1,4	3,0	15	30	22	43	0,013
M12	3,60	7,40	4,03	16,53	6,0	35	4,0	2,7	2,0	4,0	24	50	40	80	0,020
M16	7,21	12,38	7,48	21,27	7,5	40	5,0	3,2	2,5	5,0	36	58	44	113	0,044