

SM 1280

DIN 6321 (alte Norm)

Auflagebolzen

Location pins

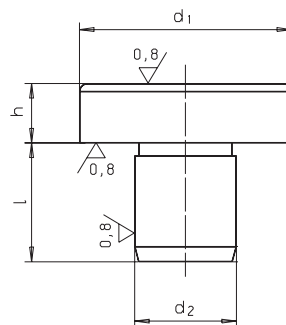

	Catalog No.	d₁	X	h
	SM 1280	16	X	013.00



Stahl, gehärtet
steel, hardened

mm

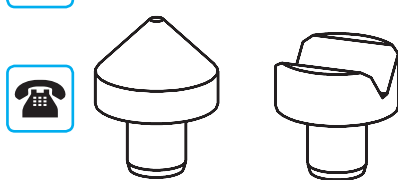

RoHS
Konform
Compliant

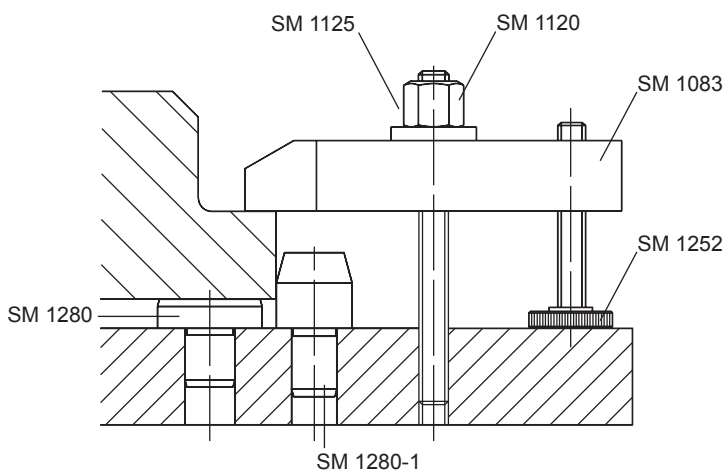

4

Reinigen mit
SM 1306
Clean with
Seite 360

Kleben mit
SM 1300
Lock with
Seite 356



d ₁ Ø	h h9	€	d ₂ Ø n6	l	kg
06	002.50	2,87	04	6,5	0,001
	004.50	2,95	04	8,5	0,002
	005.00	2,07	04	6,0	0,002
08	004.00	5,05	05	8,0	0,003
	007.00	5,15	05	8,0	0,004
10	004.50	3,19	06	8,5	0,004
	008.00	2,30	06	8,0	0,006
12	006.00	5,35	06	10,0	0,008
	010.00	5,50	06	10,0	0,011
16	005.00	2,80	08	10,0	0,011
	013.00	3,76	08		0,024
20	006.00	5,43	10	12,0	0,022
	012.00	5,50	10		0,025
25	008.00	5,59	12	14,0	0,041
	020.00	7,15	12		0,087
	030.00	8,74	12		0,130
30	025.00	13,70	16	20,0	0,170
	040.00	15,76	16		0,250
	050.00	18,42	16		0,310
	065.00	21,79	16		0,390
	080.00	23,03	20		0,485
	100.00	25,56	20		0,600
40	013.00	14,91	20		0,175
	032.00	20,91	20		0,360

