

SM 1087

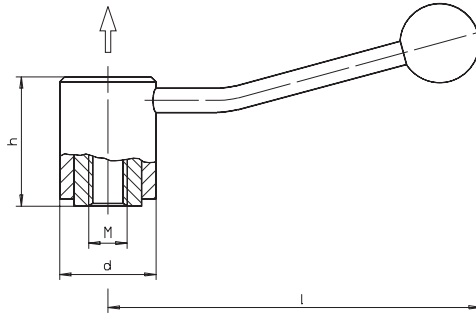

Rastenspannhebel Adjustable clamping levers



Catalog No.	Size
SM 1087	M16



Stahl, brüniert
steel, blackened



mm



Der Rastenspannhebel ersetzt den Schraubenschlüssel und ist vorteilhaft, wenn beim Spannen oft und schnell gewechselt werden muss.

You can use as a key way.



✓RoHS
Konform
Compliant



Größe Size	€	d Ø	h	l	kg
M12	51,70	33	48	135	0,360
M16	58,85	40	64	151	0,620

SM Griffelemente in verschiedenen Formen und Farben, z. B.:

SM Grip-Elements in different forms and colours for example:

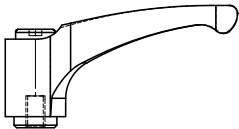

SM 1180

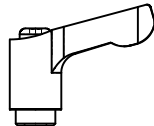

SM 1182

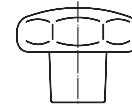

SM 1205

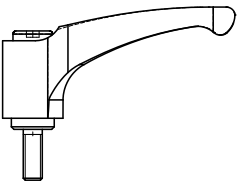

SM 1181

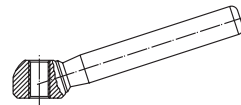

SM 1193

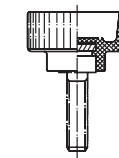

SM 1261

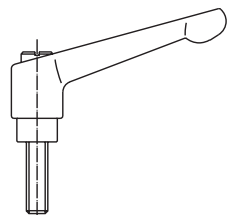

SM 1188

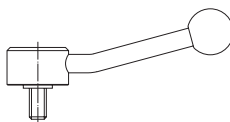

SM 1194

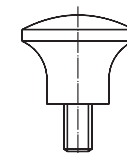

SM 1267

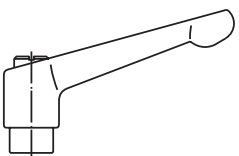

SM 1189

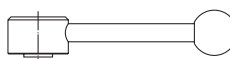

SM 1195

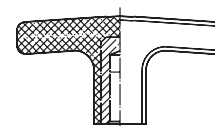

SM 1268