

2



Catalog No.	Form	Size	Material
SM 1016	K	M06	HSS



HSS: Hochleistungsschnellstahl
HSS: heavy-duty high-speed steel



Gehärtet, angelassen, allseitig feinstgeschliffen, entspannt und anschließend Sechskant formpoliert.
Hardened and annealed, all sides precision-ground. Hexagon polished.



HSS = HRc 64 + 2



Dieser Stempel ist mit entsprechendem Hohl-schliff auf Drehmaschinen auch als Räumwerkzeug einsetzbar.
This punch with a hollow ground can be used on lathes also as a broach.



mm



TIN beschichtet
titanium nitride coatings

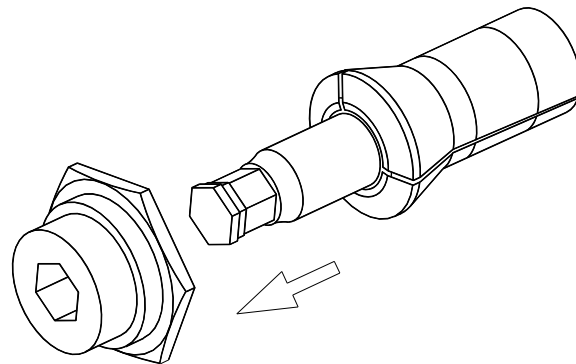

Größe für Size for DIN 912	€	D Ø f7	SW 0 -0,02	L +/- 0,1	a +/- 0,1	b + 0,3 0	c + 0,5 0	d Ø 0 -0,5	r	
	HSS									
M03	31,88	4,0	2,580	36	0,60	1,00	2,30	1,00		
M04	31,88	5,0	3,080		0,70	1,15	3,00	1,20	5	
M05	31,88	6,0	4,095		0,80	1,25	4,00	1,90	5	
M06	32,89	7,0	5,140		1,15	1,80	5,00	1,90	5	
M08	32,89	7,5	6,140		1,30	1,90	6,50	2,50		
M10	45,83	10,0	8,175		1,85	2,50	7,50	3,00	6	
M12	55,79	12,0	10,175		2,35	3,10	8,40	3,60	6	
M14	99,63	14,5	12,212	47	*	*	10,00	*		
M16	119,52	17,0	14,212		*	*	13,50	*	8	
M18	137,46	18,0	14,212		52	*	*	13,50	*	8
M20	159,38	20,0	17,230		55	*	*	15,00	*	8