

Stifte in Sonderform - Pins in special forms

ANFRAGE **BESTELLUNG**

Bestell-Nr. / Order No.: _____ Kundennr. / Cust. no.: _____

Firma / Company: _____ Tel.: _____

Abt. / Dept. Name: _____ E-mail: _____

Straße / Street: _____ Datum / Date: _____

PLZ - Ort / ZIP - City: _____ Unterschrift / Signature: _____

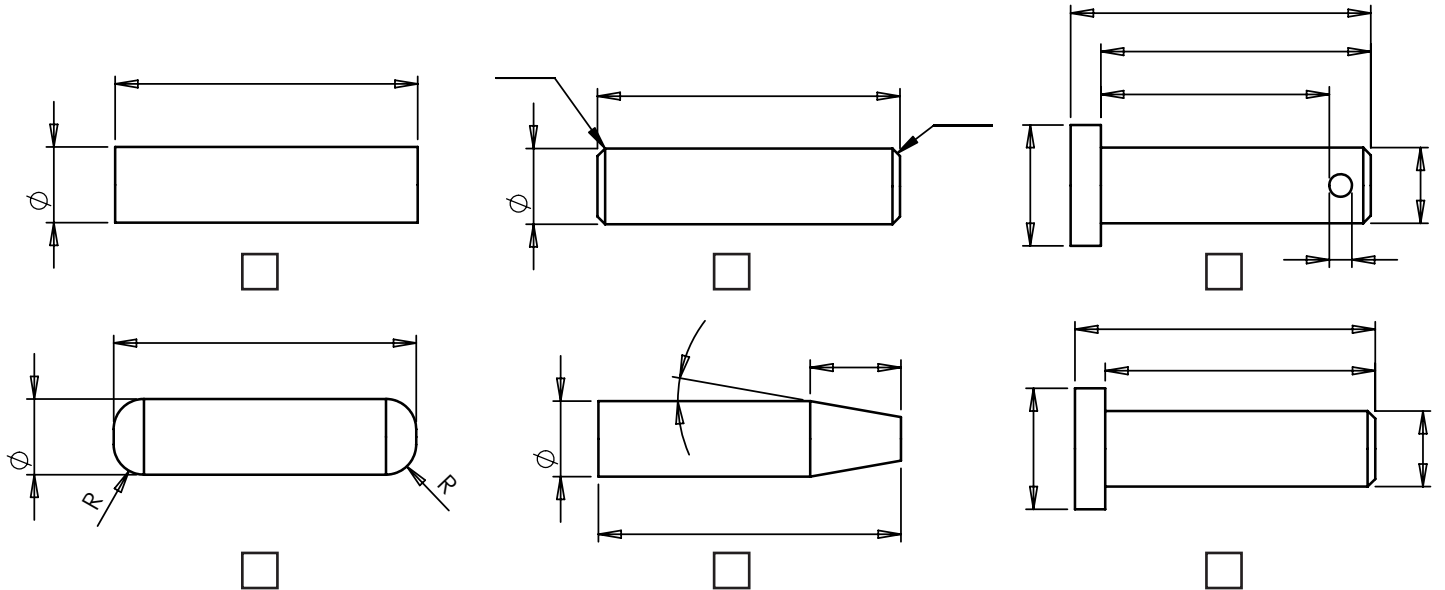

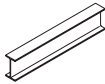
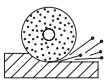
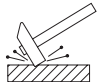
			Stück	Passung / Toleranz		Andere Formen nach Kundenwunsch
				außen	Länge	
1.0715 <input type="checkbox"/>	unbehand. <input type="checkbox"/>	HRc 40 <input type="checkbox"/>	1 <input type="checkbox"/>	n6 <input type="checkbox"/>	±0,005 <input type="checkbox"/>	
1.7131 <input type="checkbox"/>	verzinkt <input type="checkbox"/>	HRc 45 <input type="checkbox"/>	10 <input type="checkbox"/>	m6 <input type="checkbox"/>	±0,01 <input type="checkbox"/>	
1.3505 <input type="checkbox"/>	brüniert <input type="checkbox"/>	HRc 50 <input type="checkbox"/>	25 <input type="checkbox"/>	h6 <input type="checkbox"/>	±0,05 <input type="checkbox"/>	
1.3343 <input type="checkbox"/>	vernickelt <input type="checkbox"/>	HRc 55 <input type="checkbox"/>	50 <input type="checkbox"/>	h7 <input type="checkbox"/>	±0,1 <input type="checkbox"/>	
1.4301 <input type="checkbox"/>	chem. vern. <input type="checkbox"/>	HRc 60 <input type="checkbox"/>	75 <input type="checkbox"/>	h9 <input type="checkbox"/>	±0,2 <input type="checkbox"/>	
1.4305 <input type="checkbox"/>	verchromt <input type="checkbox"/>	HRc 65 <input type="checkbox"/>	100 <input type="checkbox"/>	g6 <input type="checkbox"/>	±0,3 <input type="checkbox"/>	
1.4112 <input type="checkbox"/>	poliert <input type="checkbox"/>	HRc <input type="checkbox"/>	200 <input type="checkbox"/>	f7 <input type="checkbox"/>	<input type="checkbox"/>	
1.4571 <input type="checkbox"/>	eloxiert <input type="checkbox"/>	<input type="checkbox"/>	500 <input type="checkbox"/>	<input type="checkbox"/>		
MS 58 <input type="checkbox"/>	gerändelt <input type="checkbox"/>	<input type="checkbox"/>	1000 <input type="checkbox"/>			
Aluminium <input type="checkbox"/>	gekordelt <input type="checkbox"/>	<input type="checkbox"/>	5000 <input type="checkbox"/>			
Kunststoff <input type="checkbox"/>	<input type="checkbox"/>	<input type="checkbox"/>	10000 <input type="checkbox"/>			
Hartmetall <input type="checkbox"/>	<input type="checkbox"/>	<input type="checkbox"/>	50000 <input type="checkbox"/>			
Sinterbronze <input type="checkbox"/>	<input type="checkbox"/>	<input type="checkbox"/>	<input type="checkbox"/>			
<input type="checkbox"/>	<input type="checkbox"/>	<input type="checkbox"/>				

Bemerkungen: _____



Wir produzieren für Sie Norm- und Präzisionsteile

Bohrbuchsen und Zubehör / Drill Bushes and Accessories



Anwendungsbeispiele für Bohrbuchsen / Examples for Drill Bushes

34 + 42

Elemente für den Werkzeugbau / Elements for Tool Manufacture



Anwendungsbeispiele für Lochstempel / Examples for Punches

52 + 57

Spannelemente / Clamps



Maschinen- und Vorrichtungselemente / Machine + Fixture Elements



Bedienelemente / Operating Elements



Schnellspanner / Quick-Action Clamps



Klebstoffe und Hilfsmittel / Adhesives and Auxiliary Aids



Messmittel / Measuring Devices



Kopieren & Faxen !

Bitte senden Sie uns Ihre kompletten Verkaufsunterlagen

Copy and fax it !

please send us your latest catalogue

Company:

Adress :

Attention:

Departm.: