

SM 1250

DIN 464

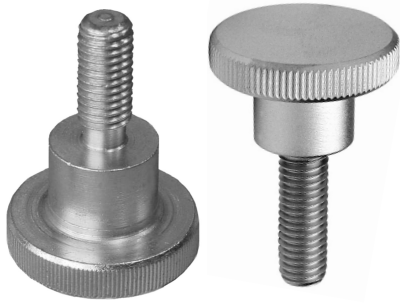

	Catalog No.	d₁	X	l	Material
	SM 1250	M03	X	16	Ni



St: Stahl, verzinkt Güte 5.8
St: steel, zinc plated grade 5.8
Ni:



mm



Gewinde bis zum Kopf, Kopffläche feingedreht
thread up to the head, visible face fine turned



MS: Messing
MS: brass

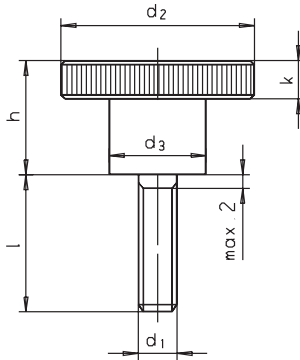

Hohe Rändelschrauben

Knurled thumb screws

d ₁ Ø	l	€		d ₂ Ø	d ₃ Ø	h	k	kg
		St	Ni					
M03	06	0,54	-	12	6	7,5	2,5	0,004
	10	0,54	1,39					0,004
	12	0,54	1,43					0,005
	16	0,54	1,75					0,005
M04	05	0,51	-	16	8	9,5	3,5	0,007
	08	0,58	1,43					0,008
	10	0,64	1,49					0,008
	12	0,67	1,54					0,009
	16	0,70	1,64					0,009
	20	0,82	1,85					0,010
	25	1,11	2,27					0,010
M05	06	0,82	-	20	10	11,5	4,0	0,014
	08	0,83	-					0,015
	10	0,86	1,75					0,015
	12	0,88	1,80					0,016
	16	0,93	1,96					0,016
	20	1,04	2,14					0,017
	25	1,12	2,34					0,017
	30	1,47	2,46					0,017
M06	08	1,13	-	24	12	15,0	5,0	0,027
	10	1,16	-					0,028
	12	1,26	2,44					0,028
	16	1,22	2,64					0,028
	20	1,33	2,80					0,029
	25	1,51	3,08					0,030
	30	1,67	3,32					0,031
	35	1,80	3,78					0,032
M08	12	1,74	-	30	16	18,0	6,0	0,055
	16	1,76	3,73					0,056
	20	1,94	4,06					0,057
	25	2,17	4,45					0,058
	30	2,32	4,83					0,060
	35	2,69	5,22					0,062
	40	2,98	-					0,063
	M10	15	2,70					-
20		2,98	-	0,109				
25		3,30	-	0,111				
30		3,56	-	0,113				
35		3,98	-	0,116				
40		4,18	-	0,117				

SM 1251

DIN 466

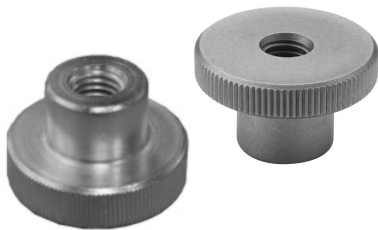

	Catalog No.	d₁	Material
	SM 1251	M03	St



St: Stahl, verzinkt Güte 5.8
St: steel, zinc plated grade 5.8
Ni:



MS: Messing
MS: brass



mm

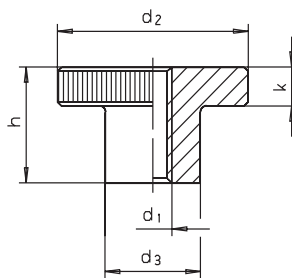

Hohe Rändelmuttern

Knurled nuts

d ₁ Ø	€		d ₂ Ø	d ₃ Ø	h	k	kg
	St	Ni					
M03	0,23	-	12	6	7,5	2,5	0,003
M04	0,24	0,92	16	8	9,5	3,5	0,007
M05	0,38	1,30	20	10	11,5	4,0	0,013
M06	0,50	1,80	24	12	15,0	5,0	0,023
M08	0,88	2,30	30	16	18,0	6,0	0,044
M10	1,46	3,75	36	20	23,0	8,0	0,087
M12	1,70	-	40	22	25,0	10,0	0,118