

Catalog No.	Form	d ₁	X	d ₂	Type
SM 1213	D	140	X	16	B

Handrad: Edelstahl-Feinguss rostfrei 1.4308
Nabe bearbeitet,
Radkranz gedreht,
matt gestrahlt,
drehbarer Zylindergriff:
Kunststoff, Duroplast
schwarz, glänzend
Achsteil: Edelstahl rostfrei 1.4301

handle:
stainless steel precision casting 1.4308
hub machined,
rim turned,
matte shot-blasted
revolving handle
plastic, Duroplast
black, shiny
spindle:
stainless steel 1.4301

Mögliche Kombinationen:

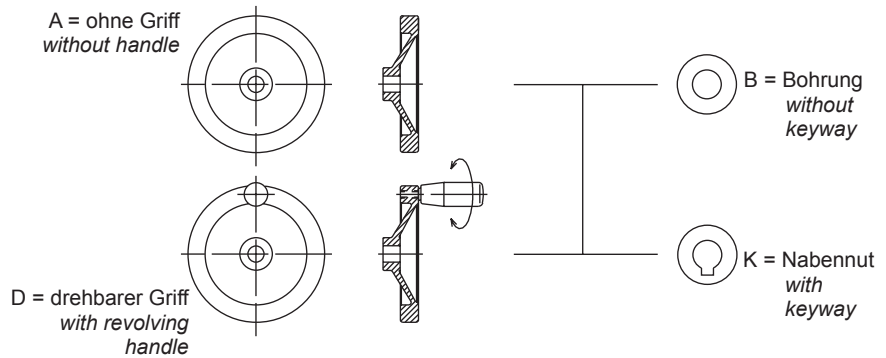

Form A: ohne Griff / without handle
Form D: drehbarer Griff / with revolving handle

Genügen hygienischen Anforderungen.
Duroplast als Material der Zylindergriffe bietet generell eine gute Beständigkeit gegenüber chemischen Einflüssen.
The stainless steel-handwheels complies with the requirements of hygiene standards.
Duroplast as the material of the cylinder handles generally offers good resistance to chemical influences.

Type B: ohne Nabennut + Bohrungsdurchmesser / without keyway + bore diameter
Type K: mit Nabennut + Bohrungsdurchmesser / with keyway + bore diameter

d ₁ ∅	Form A Form D		d ₃ ∅	b	l ₁	l ₂ ≈	l ₃ ≈	r	Griff handle ∅	Speichen-Anzahl Number of spokes	kg	
	d ₂ H8 Bohrung / Bore ∅										Type K	
	Type B / K										Form A	Form D
100	10	10	20	7	15	27,5	45	44	18	3	0,240	0,255
	12	12									0,220	0,240
125	12	12	24	9	16	28,5	55	55	21	3	0,420	0,440
	14	14									0,400	0,420
140	14	14	28	10	18	30,5	70,5	62	23	3	0,640	0,750
	16	16									0,600	0,680
160	14	14	31	11	20	35,5		71		3	0,900	0,940
	16	16									0,860	0,900
200	18	18	36	14	23	39		90		3	0,900	0,940
	20	20									0,860	0,900