

SM 1275-61

Druckstück federnd mit verlängertem Druckbolzen Spring plunger / Spring thrust pad with extended pressure bolt

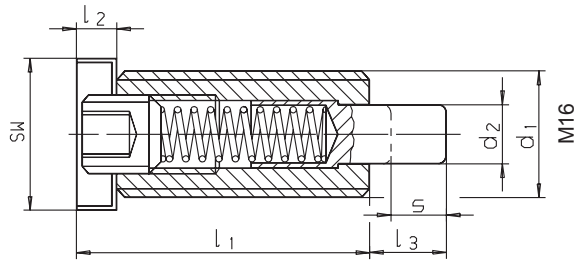
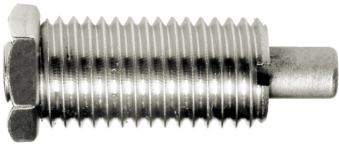

Catalog No.
SM 1275-61

Edelstahl rostfrei, Bolzen gehärtet
stainless steel, pin hardened

mm



Reinigen mit
SM 1306
Clean with

Sichern mit
SM 1301
Lock with

* = statistischer Mittelwert /
statistical average value

d ₁ Ø	d ₂ Ø	SW	l ₁	l ₂	l ₃	s	Druck / Pressure [N] ≈*		kg
							Anfang Start	Ende End	
16	7,5	17	36,5	4,5	10	8,5	20	50	0,039

SM 1275-62

Raststück für federnde Druckstücke Ball button for spring plungers



Catalog No. | **d₁**
SM 1275-62 | 08

Stahl, gehärtet und geschliffen
steel, hardened and ground

mm

Raststücke SM 1275-62 werden in Verbindung mit federnden Druckstücken eingesetzt, wenn eine abriebfeste und genaue Arretierung erforderlich ist. Insbesondere empfiehlt sich ihre Verwendung bei Druckstücken mit verstärktem Federdruck.

The ball buttons SM 1275-62 are used in connection with spring plungers, if an abrasion-proof and exact lock is required. The application is especially recommended for spring plungers with reinforced spring pressure.



Reinigen mit
SM 1306
Clean with

Sichern mit
SM 1301
Lock with

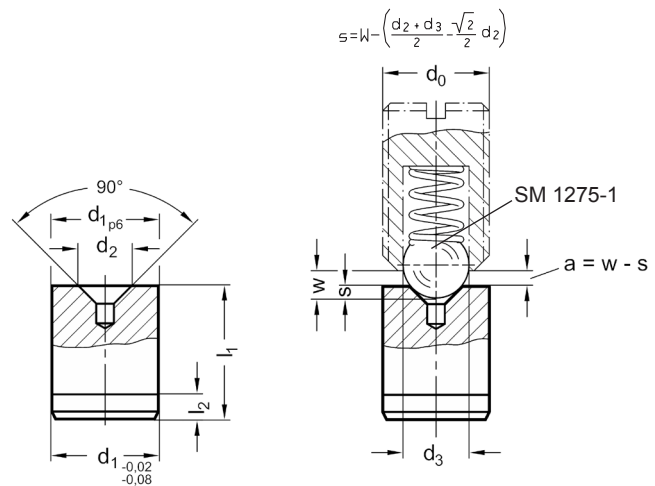

d ₁ Ø	d ₂ Ø	d ₃ Ø	l ₁	l ₂	w	für / for SM 1275-1K	für / for SM 1275-1B	für / for SM 1275-2	kg
04	1,8	siehe betr. SM-Nr. / see relevant SM-number	± 0,05	5	1,5	M04	M04	M04	0,001
06	2,5		8	1,5	M06	M06	M06	0,002	
08	3,5		10	2,0	M08	M08	M08	0,004	
10	4,5		12	2,0	M10	M10	M10	0,007	
12	6,0		14	2,5	M12	M12	M12	0,012	
16	7,5		18	2,5	M16	M16	M16	0,026	
20	8,5		22	3,0	M20	M20	M20	0,052	

