

# SM 1000-03 Ausgleich-/Einpassbuchse Aluminium Bushing for equalization, aluminium



	<b>Catalog No.</b>	<b>d<sub>1</sub></b>	<b>X</b>	<b>d<sub>2</sub></b>	<b>X</b>	<b>l</b>
	SM 1000-03	05	X	06	X	08

Aluminium  
aluminium

passiviert  
surface passivated

Mit dieser Buchse können kleinere Normteile in schon vorhandene, größere Bohrungen eingeklebt werden.  
Andere Abmessungen und Formen siehe SM 1273-6.

*This bushing enables gluing of smaller standard parts into already existing, larger boreholes*

*Other dimensions and forms see SM 1273-6.*

mm

andere Materialien und Abmessungen  
other materials and dimensions

CAD-Daten verfügbar  
CAD-files available

RoHS  
Konform  
Compliant

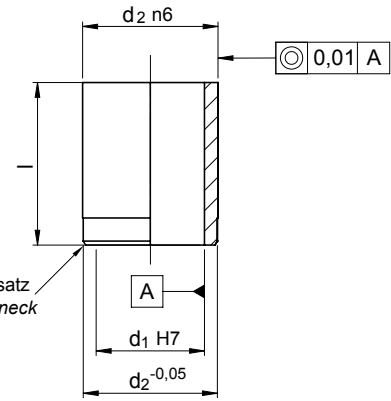

Fase oder Zentrieransatz  
chamfer or centering neck

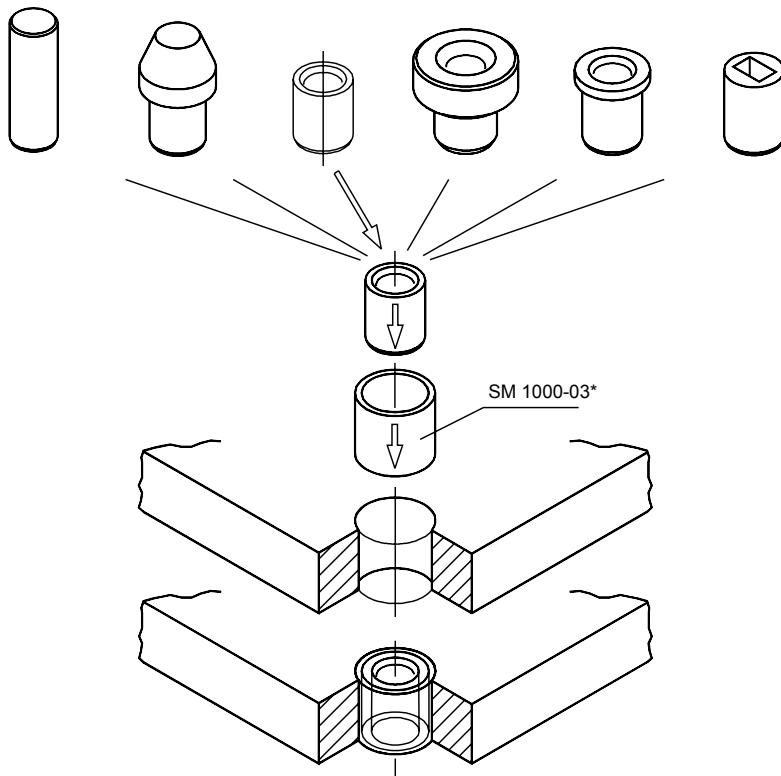

\* einpressen oder kleben  
press in or glue

d <sub>1</sub> H7 Ø	d <sub>2</sub> n6 Ø	l	l <sub>1</sub>	kg
03	04	08	2,5	0,001
05	06	08	2,5	0,001
	07			0,001
	08			0,001
06	07	10	3,0	0,001
	08			0,001
07	10	10	3,0	0,001
	08			0,001
	12			0,002
	10			0,001
08	10	08	10	0,001
	12			0,001
	10			0,002
10	12	12	4,0	0,002
	15			0,002
	18			0,005
12	15	10	4,0	0,004
	18			0,004
	12			0,005
	22			0,010
15	18	16	5,0	0,002
	12			0,002
	22			0,009
	26			0,009
20	30	25		0,016
22	26	12		0,005
		24		0,010
26	30	28		0,014