

Catalog No.	d ₁	d ₂	l	Material
SM 1020-1	07.0	05.1	4.0	NI



NI: Edelstahl rostfrei, gehärtet
NI: stainless steel, hardened



- Präzise Positionierung der Werkstücke.
- Aufnahme von Querkräften.
- Platzsparende Alternative zu Zylinderstiften.
- Keine zusätzliche Bohrungen für Zylinderstifte.

- Precisely positioning of the workpiece
- Precisely holding of fix shear forces.
- Space-saving alternative to dowel pins.
- No additional drill holes for dowel pins.



andere Abmessungen und Werkstoffe
other dimensions and materials



mm

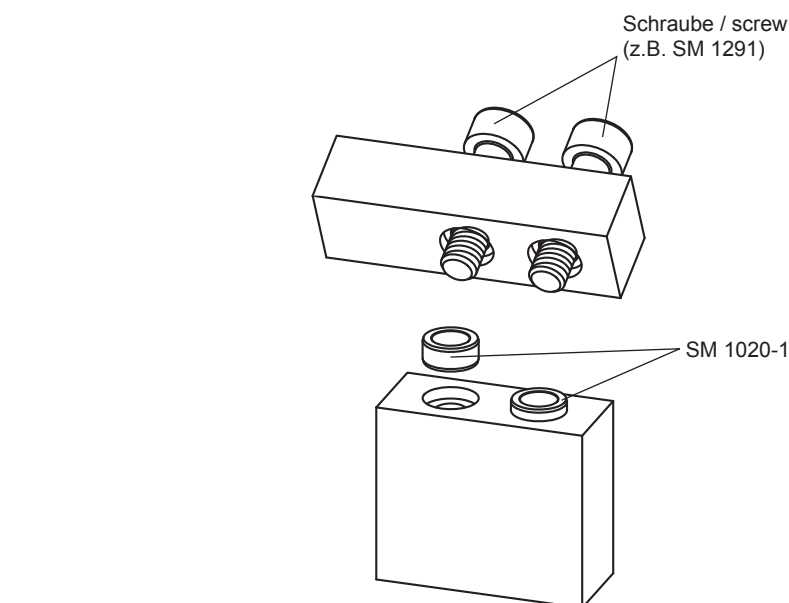

d ₁	d ₂	l	für / for Schraube screw	kg
02,0	01,3	2,0	M01,2	0,001
02,5	01,7	2,0	M01,6	0,001
03,0	02,1	2,0	M02	0,001
03,5	02,1	3,0	M02	0,001
04,0	02,6	4,0	M02,5	0,001
05,0	03,1	4,0	M03	0,001
05,0	03,1	4,4	M03	0,001
06,0	04,1	4,0	M04	0,001
06,0	04,1	5,4	M04	0,001
07,0	05,1	4,0	M05	0,001
08,0	05,1	5,4	M05	0,001
09,0	06,1	4,0	M06	0,001
10,0	06,2	6,7	M06	0,001
10,0	08,1	4,0	M08	0,001
11,0	08,1	4,0	M08	0,001
12,0	08,2	6,7	M08	0,003
12,0	10,1	4,0	M10	0,001
12,0	10,1	6,6	M10	0,002
13,0	10,0	4,0	M10	0,002
14,0	10,2	8,6	M10	0,005
14,0	12,1	6,6	M12	0,003
15,0	10,1	4,0	M10	0,003
16,0	12,1	6,6	M12	0,004
16,0	12,2	8,6	M12	0,006
20,0	14,1	10,0	M14	0,013
22,0	16,2	13,6	M16	0,019
28,0	21,0	17,6	M20	0,037

