

SM 1083-1

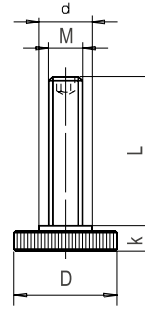

Stützschrauben Adjusting screws



	Catalog No.	M	X	L
	SM 1083-1	M10	X	39

Vergütungsstahl, Festigkeitsklasse 8.8
heat treated steel, grade 8.8

mm



M x L	D	d	k	kg
	Ø	Ø		
M10 x 39	30	16	08	0,052
M12 x 49	36	20	10	0,096
M12 x 94				0,145
M16 x 55	42	25	13	0,180
M16 x 90				0,230
M20 x 69	50	25	16	0,320
M20 x 109				0,400
M24 x 87	60	34	20	0,590
M24 x 137				0,820

3

SM 1084



Spanneisen verstellbar, gekröpft Adjustable clamp with goose-neck

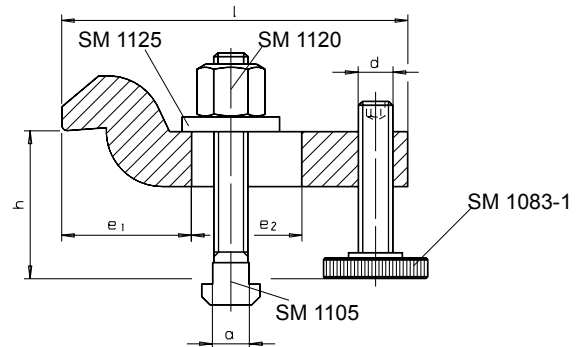

	Catalog No.	Form	a
	SM 1084	A	16 + 18

Vergütungsstahl, lackiert
heat treated steel, varnished

mm

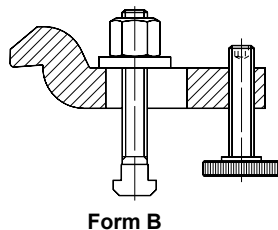
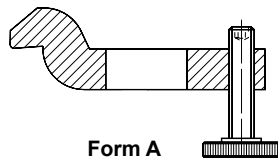

a	h	ähnl. / like DIN 6316 b ₁ x l	SM 1105 T-Nutenschraube T-bolts	d	e ₁	e ₂	kg
				Ø			
Form A							
10	22 - 51	11 x 100	-	M10	36,0	32	0,345
12 + 14	28 - 65	14 x 125	-	M12	44,0	40	0,760
16 + 18	36 - 75	18 x 160	-	M16	51,5	50	1,518
20 + 22	43 - 92	22 x 200	-	M20	59,0	70	2,670
24 + 28	52 - 115	26 x 200	-	M24	76,5	60	3,810
Form B							
10	22 - 46	11 x 100	M10 x 10 x 080	M10	36,0	32	0,440
12	28 - 58	14 x 125	M12 x 12 x 100				0,910
14	28 - 56	14 x 125	M12 x 14 x 100	M16	51,5	50	0,927
16	36 - 71	18 x 160	M16 x 16 x 125				1,860
18	36 - 69	18 x 160	M16 x 18 x 125				1,875
20	43 - 92	22 x 200	M20 x 20 x 160	M20	59,0	70	3,320
22	43 - 92	22 x 200	M20 x 22 x 160				3,323