

Catalog No.	Form	d ₁	d ₂	Material
SM 1146	C	20	M10	NI

Form C und F
ST: Körper: Vergütungsstahl, vergütet
 Kugel: Kugellagerstahl, gehärtet
Form C
NI: Körper: Edelstahl rostfrei 1.4057, vergütet
 Kugel: Edelstahl rostfrei 1.3541, vernickelt

Form C: Kugel abgeflacht, Auflagefläche plan
Form F: Kugel abgeflacht, Auflagefläche geriffelt
Form C: flat-faced ball, plain surface
Form F: flat-faced ball, ridged surface

Kugel Hartmetall
ball carbide



Form C and F

ST: body: heat-treated steel, tempered
 ball: ball-bearing steel, hardened

Form C

NI: body: stainless steel 1.4057, heat-treated
 ball: stainless steel 1.3541, nickel-plated

Reinigen mit
SM 1306
Clean with

Kleben mit
SM 1301
Lock with

d ₁	d ₂	d ₃	l ₁	l ₂	Kugel Ball Ø	SW	F max. stat. [kN]	kg
13	M06	7,2	13	8	10	11	10	0,014
13	M08	7,2	13	8	10	11	10	0,016
20	M08	10,5	18	10	16	17	25	0,049
20	M10	10,5	18	10	16	17	25	0,051
20	M12	10,5	18	12	16	17	25	0,054
30	M16	20,0	27	16	25	27	90	0,190
50	M20	34,5	35	20	40	41	165	0,639
50	M24	34,5	35	24	40	41	165	0,673

mm

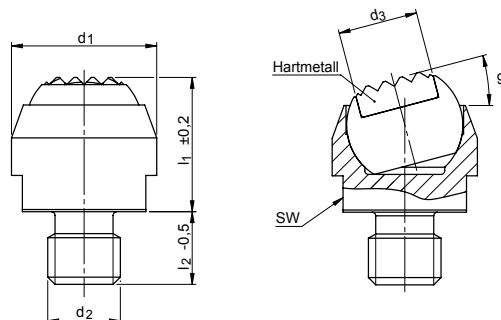

Catalog No.	d ₁	d ₂	Material
SM 1146-01	13	M06	ST

ST: Körper: Vergütungsstahl, vergütet, phosphatiert
NI: Körper: Edelstahl rostfrei 1.4057, vergütet
 Kugel: Hartmetall, geriffelt, vernickelt

Diese Bolzen sind besonders geeignet für Gussteile (harte Gusschaut) als Auflagen, Druckstücke und für den Einbau in Spannelemente. Kugel mit Verdreh-sicherung.

To be used as stops, supports and thrust pads, especially for cast parts (hard casting crust) and fitted to clamping elements. Ball secured against turning.

ST: body: steel, heat-treated steel, tempered, phosphated
NI: body: stainless steel 1.4057, heat-treated
 ball: carbide, ridged, nickel-plated

d ₁	d ₂	d ₃	l ₁	l ₂	SW	Kugel Ball Ø	kg
13	M06	8,3	13,0	8,0	11	10,0	0,012
13	M08	8,3	13,0	8,0	11	10,0	0,016
20	M08	13,1	18,0	10,0	17	16,0	0,049
20	M10	13,1	18,0	10,0	17	16,0	0,050
20	M12	13,1	18,0	12,0	17	16,0	0,055
30	M16	20,0	27,0	16,0	27	25,0	0,190
50	M20	34,5	35,0	20,0	41	40,0	0,639
50	M24	34,5	35,0	24,0	41	40,0	0,673

Reinigen mit
SM 1306
Clean with

Kleben mit
SM 1301
Lock with

mm

